

Zgrzewanie łukowe Bolec gwintowany typ MD

Robiony na zamówienie ze wszystkich standardowych materiałów.

Strona:

Pierścień: UF 74
Uchwyt do pierścieni: KRH 79
Uchwyt: BH 79

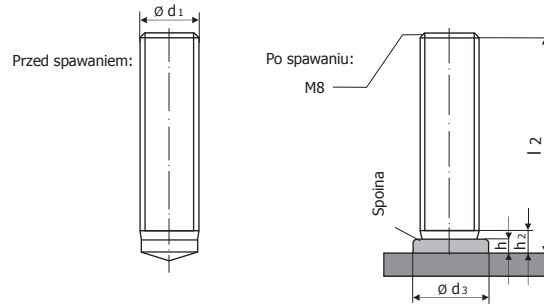

1) W związku z przyjętą tolerancją wagową dane mają wartości przybliżone.
Dla zastosowań, w których wymagany jest ciągły gwint aż do spoiny, mogą być dostarczone bolce gwintowane typu MD. Inne wymiary, gwinty i materiały po konsultacji.



Cena netto w € za 100 sztuk

Gwint x długość	<1.000	1.000	2.500	5.000	10.000	25.000	50.000	Artykuł nr
M6x15								203080615
M6x20								203080620
M6x25								203080625
M6x30								203080630
M6x35								203080635
M6x40								203080640
M6x45								203080645
M6x50								203080650
M6x55								203080655
M6x60								203080660
M6x65								203080665
M6x70								203080670
M6x75								203080675
M6x80								203080680
M6x85								203080685
M6x90								203080690
M6x95								203080695
M6x100								203080610

Wszystkie dane w mm

d1	l2	d3	h	h2	m ¹ (kg) na 1.000
M6	15				
M6	20				
M6	25				
M6	30				
M6	35				
M6	40				
M6	45				
M6	50				
M6	55				
M6	60				
M6	65				
M6	70				
M6	75				
M6	80				
M6	85				
M6	90				
M6	95				
M6	100				



Gwint x długość	<1.000	1.000	2.500	5.000	10.000	25.000	50.000	Artykuł nr
M8x15								203080815
M8x20								203080820
M8x25								203080825
M8x30								203080830
M8x35								203080835
M8x40								203080840
M8x45								203080845
M8x50								203080850
M8x55								203080855
M8x60								203080860
M8x65								203080865
M8x70								203080870
M8x75								203080875
M8x80								203080880
M8x85								203080885
M8x90								203080890
M8x95								203080895
M8x100								203080810

d1	l2	d3	h	h2	m ¹ (kg) na 1.000
M8	15				
M8	20	11,0	3,5	5,5	5,7
M8	25	11,0	3,5	5,5	7,3
M8	30	11,0	3,5	5,5	8,9
M8	35	11,0	3,5	5,5	10,5
M8	40	11,0	3,5	5,5	12,1
M8	45	11,0	3,5	5,5	13,7
M8	50	11,0	3,5	5,5	15,3
M8	55	11,0	3,5	5,5	
M8	60	11,0	3,5	5,5	
M8	65	11,0	3,5	5,5	
M8	70	11,0	3,5	5,5	
M8	75	11,0	3,5	5,5	
M8	80	11,0	3,5	5,5	
M8	85	11,0	3,5	5,5	
M8	90	11,0	3,5	5,5	
M8	95	11,0	3,5	5,5	
M8	100	11,0	3,5	5,5	



Gwint x długość	<1.000	1.000	2.500	5.000	10.000	25.000	50.000	Artykuł nr
M10x15								203081015
M10x20								203081020
M10x25								203081025
M10x30								203081030
M10x35								203081035
M10x40								203081040
M10x45								203081045
M10x50								203081050
M10x55								203081055
M10x60								203081060
M10x65								203081065
M10x70								203081070
M10x75								203081075
M10x80								203081080
M10x85								203081085
M10x90								203081090
M10x95								203081095
M10x100								203081010

d1	l2	d3	h	h2	m ¹ (kg) na 1.000
M10	15				
M10	20	13,5	4,0	6,0	9,0
M10	25	13,5	4,0	6,0	11,5
M10	30	13,5	4,0	6,0	14,0
M10	35	13,5	4,0	6,0	16,5
M10	40	13,5	4,0	6,0	19,0
M10	45	13,5	4,0	6,0	21,6
M10	50	13,5	4,0	6,0	24,1
M10	55	13,5	4,0	6,0	26,6
M10	60	13,5	4,0	6,0	
M10	65	13,5	4,0	6,0	
M10	70	13,5	4,0	6,0	
M10	75	13,5	4,0	6,0	
M10	80	13,5	4,0	6,0	
M10	85	13,5	4,0	6,0	
M10	90	13,5	4,0	6,0	
M10	95	13,5	4,0	6,0	
M10	100	13,5	4,0	6,0	

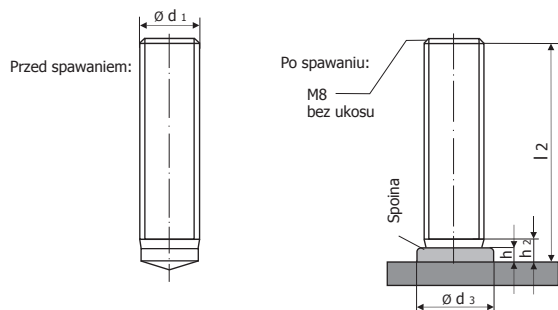

Zgrzewanie łukowe Bolec gwintowany typ MD

Robiony na zamówienie ze wszystkich standardowych materiałów.

Strona:

Pierścień: UF 74

Uchwyt do pierścieni: KRH 79

Uchwyt: BH 79

1) W związku z przyjętą tolerancją wagową dane mają wartości przybliżone.

Dla zastosowań, w których wymagany jest ciągły gwint aż do spoiny, mogą być dostarczone bolce gwintowane typu MD. Inne wymiary, gwinty i materiały po konsultacji.

I1 do wyboru przez producenta.

Jest to wskaźnik, który nie zależy od użytkownika

Cena netto w € za 100 sztuk

Gwint x długość	<1.000	1.000	2.500	5.000	10.000	25.000	50.000	Artykuł nr
M12x20								203081220
M12x25								203081225
M12x30								203081230
M12x35								203081235
M12x40								203081240
M12x45								203081245
M12x50								203081250
M12x55								203081255
M12x60			Ceny na zapytanie					203081260
M12x65								203081265
M12x70								203081270
M12x75								203081275
M12x80								203081280
M12x85								203081285
M12x90								203081290
M12x95								203081295
M12x100								203081210

Wszystkie dane w mm

d1	l2	d3	h	h2	m ³ (kg) na 1.000
M12	20				
M12	25	15,5	4,5	6,5	16,5
M12	30	15,5	4,5	6,5	20,2
M12	35	15,5	4,5	6,5	23,9
M12	40	15,5	4,5	6,5	27,5
M12	45	15,5	4,5	6,5	31,2
M12	50	15,5	4,5	6,5	34,8
M12	55	15,5	4,5	6,5	38,5
M12	60	15,5	4,5	6,5	42,2
M12	65	15,5	4,5	6,5	
M12	70	15,5	4,5	6,5	
M12	75	15,5	4,5	6,5	
M12	80	15,5	4,5	6,5	
M12	85	15,5	4,5	6,5	
M12	90	15,5	4,5	6,5	
M12	95	15,5	4,5	6,5	
M12	100	15,5	4,5	6,5	



Gwint x długość	<1.000	1.000	2.500	5.000	10.000	25.000	50.000	Artykuł nr
M16x20								203081620
M16x25								203081625
M16x30								203081630
M16x35								203081635
M16x40								203081640
M16x45								203081645
M16x50								203081650
M16x55								203081655
M16x60			Ceny na zapytanie					203081660
M16x65								203081665
M16x70								203081670
M16x75								203081675
M16x80								203081680
M16x85								203081685
M16x90								203081690
M16x95								203081695
M16x100								203081610

d1	l2	d3	h	h2	m ³ (kg) na 1.000
M16	20				
M16	25				
M16	30	20,5	7,0	9,0	36,9
M16	35	20,5	7,0	9,0	43,5
M16	40	20,5	7,0	9,0	50,2
M16	45	20,5	7,0	9,0	56,9
M16	50	20,5	7,0	9,0	63,5
M16	55	20,5	7,0	9,0	70,2
M16	60	20,5	7,0	9,0	76,8
M16	65	20,5	7,0	9,0	83,5
M16	70	20,5	7,0	9,0	
M16	75	20,5	7,0	9,0	
M16	80	20,5	7,0	9,0	
M16	85	20,5	7,0	9,0	
M16	90	20,5	7,0	9,0	
M16	95	20,5	7,0	9,0	
M16	100	20,5	7,0	9,0	



Gwint x długość	<1.000	1.000	2.500	5.000	10.000	25.000	50.000	Artykuł nr
M20x30								203082030
M20x35								203082035
M20x40								203082040
M20x45								203082045
M20x50								203082050
M20x55								203082055
M20x60								203082060
M20x65			Ceny na zapytanie					203082065
M20x70								203082070
M20x75								203082075
M20x80								203082080
M20x85								203082085
M20x90								203082090
M20x95								203082095
M20x100								203082010

d1	l2	d3	h	h2	m ³ (kg) na 1.000
M20	30				
M20	35	26,0	9,0	11,0	77,8
M20	40	26,0	9,0	11,0	88,2
M20	45	26,0	9,0	11,0	98,6
M20	50	26,0	9,0	11,0	109,1
M20	55	26,0	9,0	11,0	119,5
M20	60	26,0	9,0	11,0	129,9
M20	65	26,0	9,0	11,0	140,4
M20	70	26,0	9,0	11,0	
M20	75	26,0	9,0	11,0	
M20	80	26,0	9,0	11,0	
M20	85	26,0	9,0	11,0	
M20	90	26,0	9,0	11,0	
M20	95	26,0	9,0	11,0	
M20	100	26,0	9,0	11,0	

