

Zgrzewanie łukowe

Tulejka z gwintem wewnętrznym typ ID

Robiony na zamówienie ze wszystkich standardowych materiałów.

Strona:

Pierścień: UF 74

Uchwyt do pierścieni: KRH 79

Uchwyt: BH 79

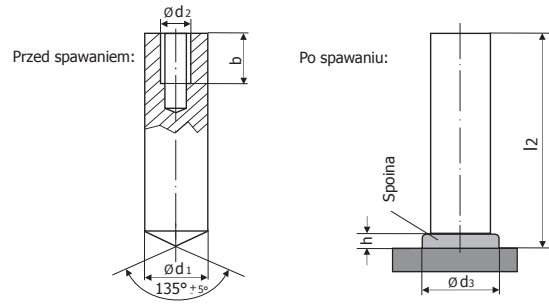

1) W związku z przyjętą tolerancją wagową dane mają wartości przybliżone.



Cena netto w € za 100 sztuk

Gwint x średnica x długość	<1.000	1.000	2.500	5.000	10.000	25.000	50.000	Artykuł nr
M6xø10x12								1130210126
M6xø10x15								1130210156
M6xø10x20								1130210206
M6xø10x25								1130210256
M6xø10x30								1130210306
M6xø10x35								1130210356
M6xø10x40								1130210406
M6xø10x45								1130210456
M6xø10x50								1130210506
M6xø10x60								1130210606
M6xø10x70								1130210706
M6xø10x80								1130210806
M6xø10x90								1130210906
M6xø10x100								1130210106

Wszystkie dane w mm

d1	d2	l2	d3	b	h	m ³ (kg) na 100
ø10	M6	12	13	6	4,0	0,71
ø10	M6	15	13	7	4,0	0,84
ø10	M6	20	13	7	4,0	1,06
ø10	M6	25	13	9	4,0	1,37
ø10	M6	30	13	9	4,0	1,67
ø10	M6	35	13	9	4,0	1,98
ø10	M6	40	13	9	4,0	2,28
ø10	M6	45	13	9	4,0	2,58
ø10	M6	50	13	9	4,0	2,89
ø10	M6	60	13	9	4,0	3,49
ø10	M6	70	13	9	4,0	4,10
ø10	M6	80	13	9	4,0	4,71
ø10	M6	90	13	9	4,0	5,32
ø10	M6	100	13	9	4,0	5,92



Gwint x średnica x długość	<1.000	1.000	2.500	5.000	10.000	25.000	50.000	Artykuł nr
M8xø12x15								1130212158
M8xø12x20								1130212208
M8xø14,6x25								1130214258
M8xø14,6x30								1130214308
M8xø14,6x35								1130214358
M8xø14,6x40								1130214408
M8xø14,6x45								1130214458
M8xø14,6x50								1130214508
M8xø14,6x55								1130214558
M8xø14,6x60								1130214608
M8xø14,6x70								1130214708
M8xø14,6x80								1130214808
M8xø14,6x90								1130214908
M8xø14,6x100								1130214108

d1	d2	l2	d3	b	h	m ³ (kg) na 100
ø12	M8	15	16	8	5,0	1,14
ø12	M8	20	16	12	5,0	1,30
ø14,6	M8	25	18,5	12	5,8	2,32
ø14,6	M8	30	18,5	12	5,8	3,45
ø14,6	M8	35	18,5	12	5,8	4,12
ø14,6	M8	40	18,5	12	5,8	4,79
ø14,6	M8	45	18,5	12	5,8	5,46
ø14,6	M8	50	18,5	12	5,8	6,13
ø14,6	M8	55	18,5	12	5,8	6,80
ø14,6	M8	60	18,5	12	5,8	7,47
ø14,6	M8	70	18,5	12	5,8	8,81
ø14,6	M8	80	18,5	12	5,8	10,15
ø14,6	M8	90	18,5	12	5,8	11,49
ø14,6	M8	100	18,5	12	5,8	12,83



Gwint x średnica x długość	<1.000	1.000	2.500	5.000	10.000	25.000	50.000	Artykuł nr
M10x ø16,2x15								11302161510
M10x ø16,2x20								11302162010
M10x ø16,2x25								11302162510
M10x ø16,2x30								11302163010
M10x ø16,2x35								11302163510
M10x ø16,2x40								11302164010
M10x ø16,2x45								11302164510
M10x ø16,2x50								11302165010
M10x ø16,2x55								11302165510
M10x ø16,2x60								11302166010
M10x ø16,2x70								11302167010
M10x ø16,2x80								11302168010
M10x ø16,2x90								11302169010
M10x ø16,2x100								11302161010

d1	d2	l2	d3	b	h	m ³ (kg) na 100
ø16,2	M10	15				
ø16,2	M10	20	21,0	10	7,0	2,81
ø16,2	M10	25	21,0	15	7,0	3,37
ø16,2	M10	30				
ø16,2	M10	35				
ø16,2	M10	40	21,0	15	7,0	5,55
ø16,2	M10	45				
ø16,2	M10	50				
ø16,2	M10	55				
ø16,2	M10	60				
ø16,2	M10	70				
ø16,2	M10	80				
ø16,2	M10	90				
ø16,2	M10	100				