

DIN 1440 - ISO 8738 - PN 82004

Norma

Podkładki okrągłe do sworzni

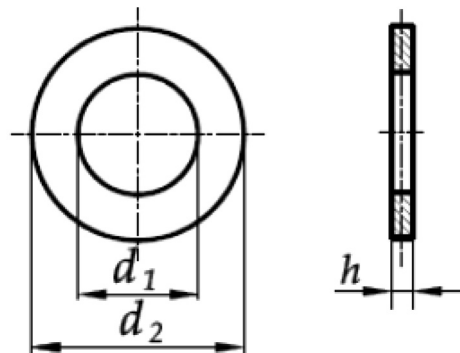

MATERIAŁY:

- Stal
- Stal nierdzewna A2, A4

POKRYCIA:

- Bez pokrycia
- Ocynk galwaniczny
- Inne na zapytanie

średnica sworznia	5	6	8	10	12	13	14	16	18	20	22
d₁ H11	5	6	8	10	12	13	14	16	18	20	22
d₂	10	12	16	20	25	25	28	28	30	32	34
h	0,8	1,6	2	2,5	3	3	3	3	4	4	4

średnica sworznia	23	24	25	26	28	30	32	33	35	36	40
d₁ H11	23	24	25	26	28	30	32	33	35	36	40
d₂	36	38	40	40	42	45	50	50	52	52	58
h	4	4	4	5	5	5	5	5	6	6	6

średnica sworznia	45	50	55	60	65	70	75	80	90	95	100
d₁ H11	45	50	55	60	65	70	75	80	90	95	100
d₂	62	68	75	80	90	95	100	110	115	150	125
h	7	8	9	9	9	10	10	12	12	12	14

* Wymiary w tabeli to wymiary standardowe

** Inne na zapytanie