

DIN 988

Norma

Podkładki dystansowe

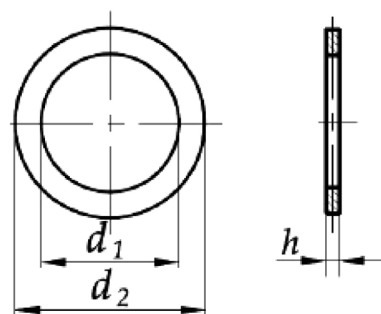

MATERIAŁY:

- Stal
- Stal nierdzewna A2, A4

POKRYCIA:

- Bez pokrycia
- Inne na zapytanie

dla gwintu	M 3	M 4	M 6	M 8	M 10	M 12	M 14
d_1	3	4	6	8	10	12	14
d_2	6	8	12	14	13	18	20
h	1	1	1,2	1,2	1,2	1,2	1,5

dla gwintu	M 15	M 16	M 17	M 18	M 20	M 22	M 25
d_1	15	16	17	18	20	22	25
d_2	21	22	24	25	28	30/32	35/36
h	1,5	1,5	1,5	1,5	2	2	2

dla gwintu	M 26	M 28	M 30	M 35	M 37	M 40	M 45
d_1	26	28	30	35	37	40	45
d_2	37	40	42	45	47	50	55
h	2	2	2,5	2,5	2,5	2,5	3

* Wymiary w tabeli to wymiary standardowe

** Inne na zapytanie

DIN 988

Norma

Podkładki dystansowe

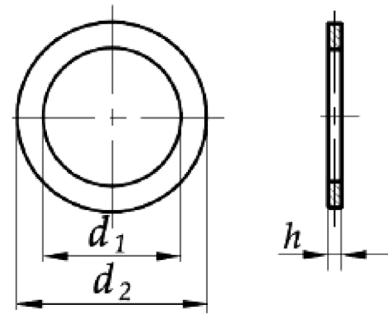

c.d.

dla gwintu	M 50	M 55	M 60	M 63	M 65	M 70	M 75
d_1	50	55	60	63	65	70	75
d_2	62/63	68	75	80	85	90	95
h	3	3	3	3	3,5	3,5	3,5

dla gwintu	M 80	M 85	M 90	M 100
d_1	80	85	90	100
d_2	100	105	110	120/125
h	3,5	3,5	3,5	3,5

* Wymiary w tabeli to wymiary standardowe

** Inne na zapytanie